

INSTALLATION BLOCK DIAGRAM

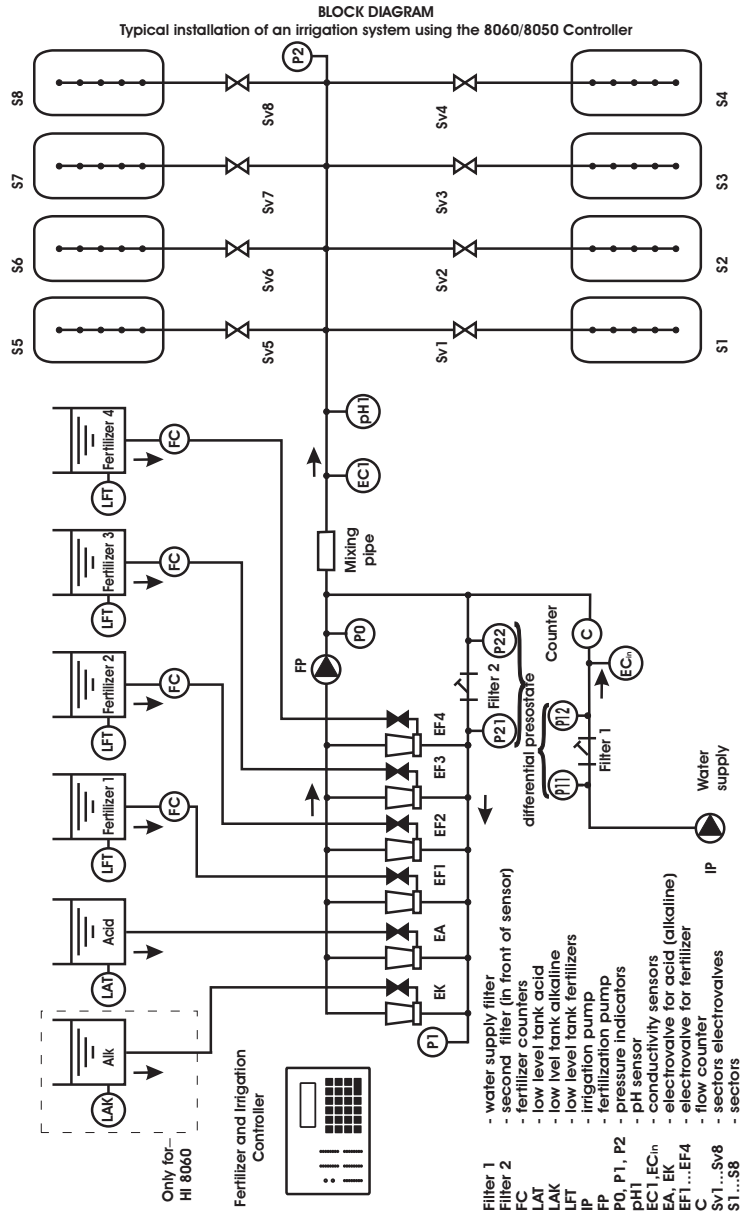

BLOCK DIAGRAM
Typical installation of an irrigation system using the 8050/8060 Controller

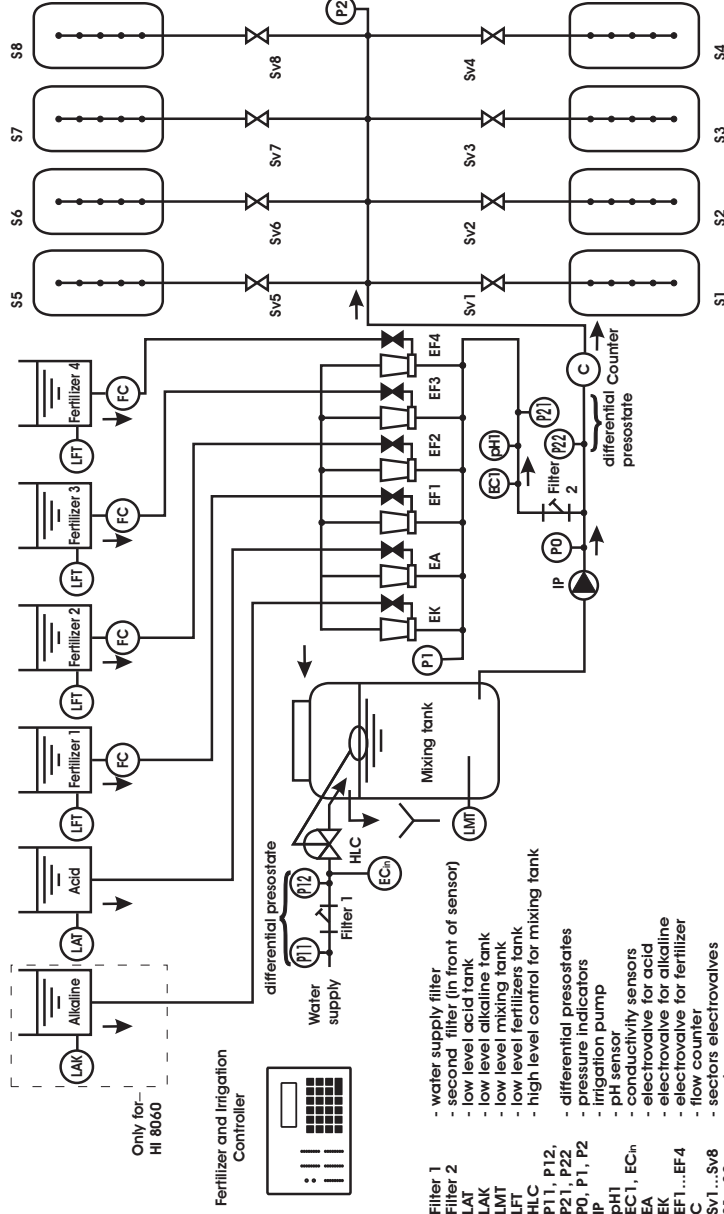

- water supply filter
- second filter (in front of sensor)
- low level acid tank
- low level alkaline tank
- low level mixing tank
- low level fertilizers tank
- high level control for mixing tank
- differential presostates
- pressure indicators
- irrigation pump
- pH sensor
- conductivity sensors
- electrovalve for acid
- electrovalve for alkaline
- electrovalve for fertilizer
- flow counter
- sectors electrovalves
- sectors
- fertilizer counters

Filter 1
Filter 2
LAT
LAK
LMT
LFT
HLC
P11, P12,
P21, P22
PO, P1, P2
IP
pH1
EC1, ECn
EA
EK
EF1...EF4
C
Sv1...Sv8
S1...S8
FC1...FC4